



31 October 2024

Q3 2024

Investor meeting

Arni Sigurdsson
Chief Executive Officer

Sebastiaan Boelen
Chief Financial Officer

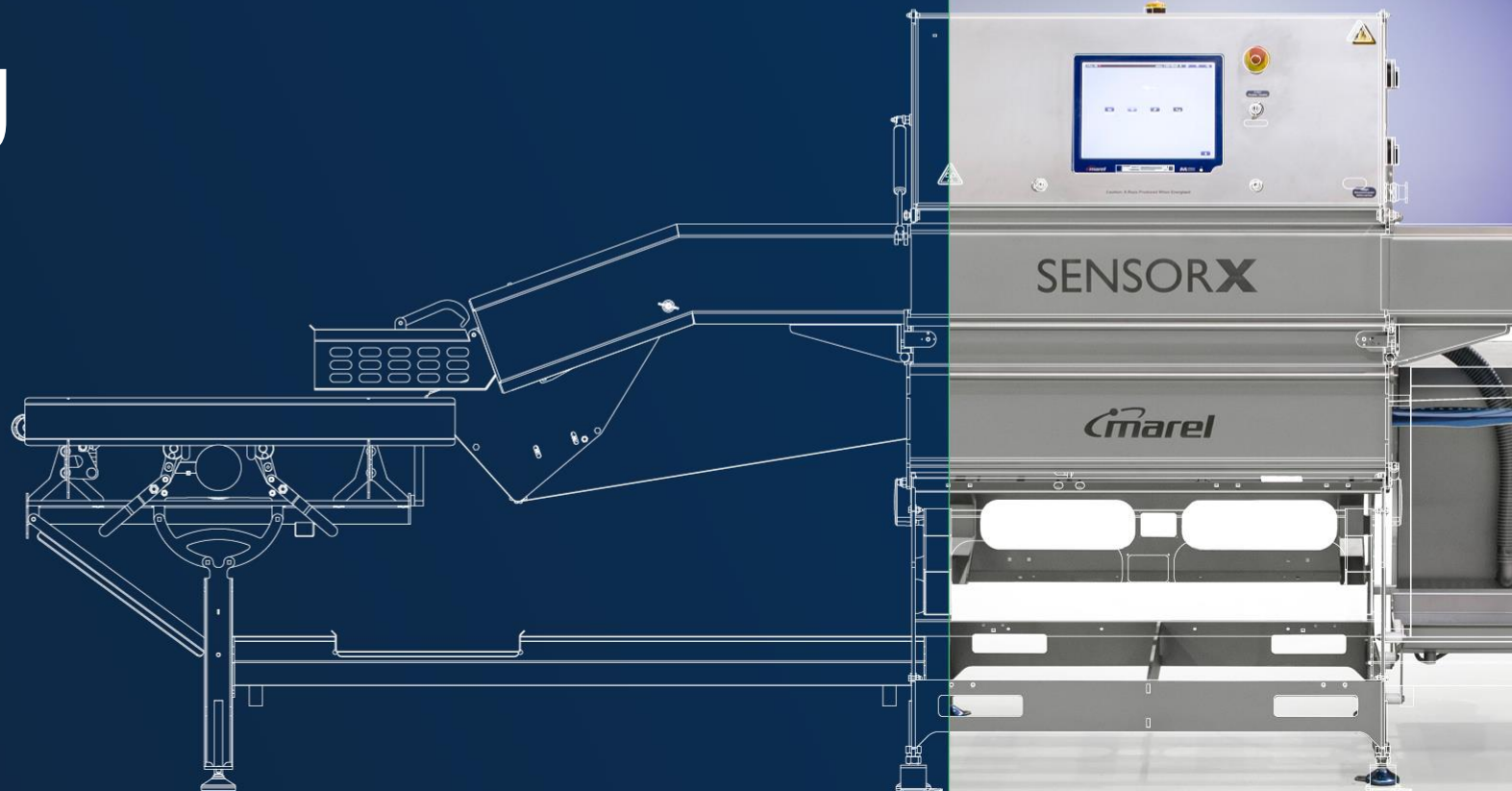

1

3Q24 financial performance

Material step up in orders received for poultry projects

Year-on-year and sequential improvement in both EBITDA margin at 13.8% and EBIT margin at 9.4%

Continued focus on profit improvement and cost actions across the business

2

Outlook for full-year 2024 and mid-term

Reiterating outlook for full-year 2024 with 13-14% EBITDA and 9-10% EBIT and low single digit revenue decline

Orders received expected to trend upwards over the coming quarters

Outlook for the mid-term reiterated

3

Update on JBT's takeover offer

Transaction targeted to close no later than 3 Jan 2025

Over 99% approval at JBT's shareholder meeting

Significant milestone with European Commission filing 23 Oct, provisional deadline 28 Nov 2024

Tender offer period for Marel shareholders extended to 20 Dec 2024

Key points to cover today

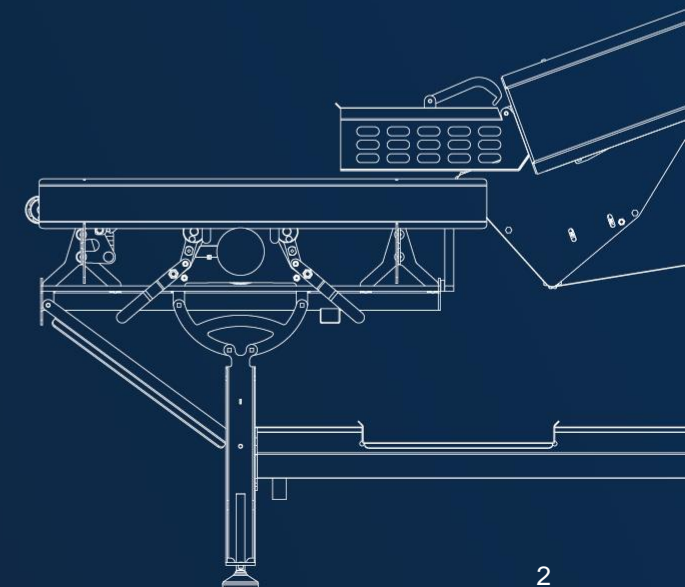

1

Financial performance

Sebastiaan Boelen
Chief Financial Officer



Executive summary

Orders received increasing to EUR 403m driven by very good project orders in Poultry, albeit order book remains low at 33% of trailing twelve months revenues.

Revenue decline of 6.8% QoQ and 4.1% YoY due to low order book. Book-to-bill ratio at 1.04 in the quarter.

Year-on-year and sequential increase in both EBITDA margin at 13.8% and EBIT margin at 9.4% in 3Q24, driven by ongoing cost actions.

Orders received expected to trend upwards over the coming quarters. Order book needs to grow to deliver necessary revenue growth and improved operational performance.

Leverage reduced to 3.75x, comfortably within leverage covenant of 4.25x.

Outlook for full-year 2024 reiterated with 13-14% EBITDA, 9-10% EBIT, and revenue decline of low single digits.

Orders received of EUR 403m and EBIT at 9.4% despite revenue decline

Orders received
EUR m

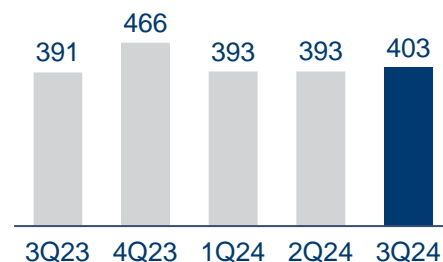

Revenues
EUR m

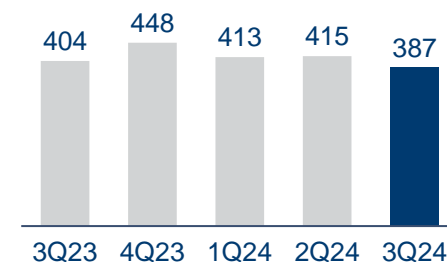

Order book
EUR m

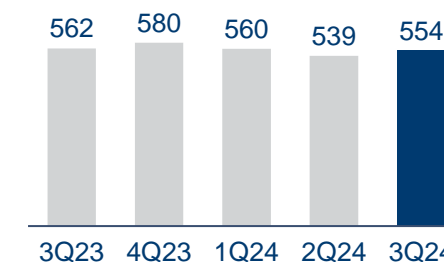

EBITDA¹ margin
%

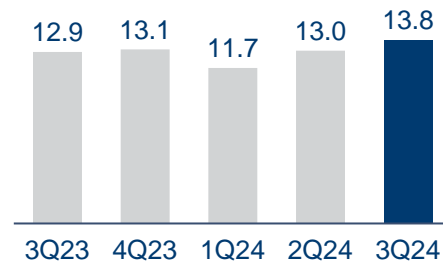

EBIT¹ margin
%

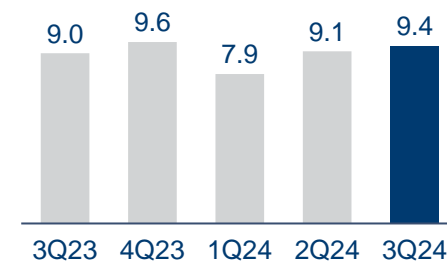

Free cash flow²
EUR m

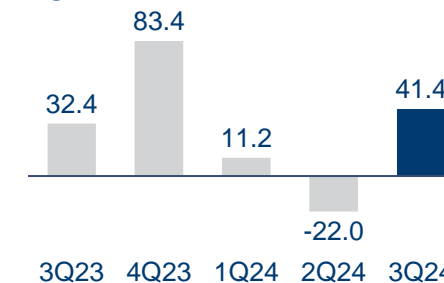

Orders received and revenues

Orders received

EUR 402.5m, up 2.3% QoQ and 3.0% YoY

Orders received driven by good project orders. Poultry had a material step up in orders received in the quarter, closing some large projects, while orders received were softer in Meat, Fish and Plant, Pet & Feed.

Orders received expected to trend upwards over the coming quarters. Market fundamentals continue to stay attractive and outlook for coming quarters is positive for Poultry and PPF. The Meat and Fish segments however continue to be soft.

Pipeline conversion to orders keeps shifting out with differing segment demand, inflation and high-interest rate environment only slowly abating and continuing geopolitical tensions. Time to secure down payments and provide financial security on orders also continues to take longer.

Revenues

EUR 386.9m, down 6.8% QoQ and 4.1% YoY

Revenues declined due to low project revenues resulting from low orders received in recent quarters and soft order book. Project revenues at EUR 188.2m in 3Q24, down 12.1% QoQ and 9.3% YoY (2Q24: 214.2m, 3Q23: 207.4m).

Recurring aftermarket revenues remains solid with underlying momentum at EUR 198.7m with a seasonal decline of 1.1% QoQ and growth of 1.3% YoY (2Q24: 201.0m, 3Q23: 196.2m), reflecting Marel's strong focus on quality service.



Material step up in Poultry project orders, while orders softer in Meat, Fish and Plant, Pet & Feed

Revenues and order evolution

EUR m

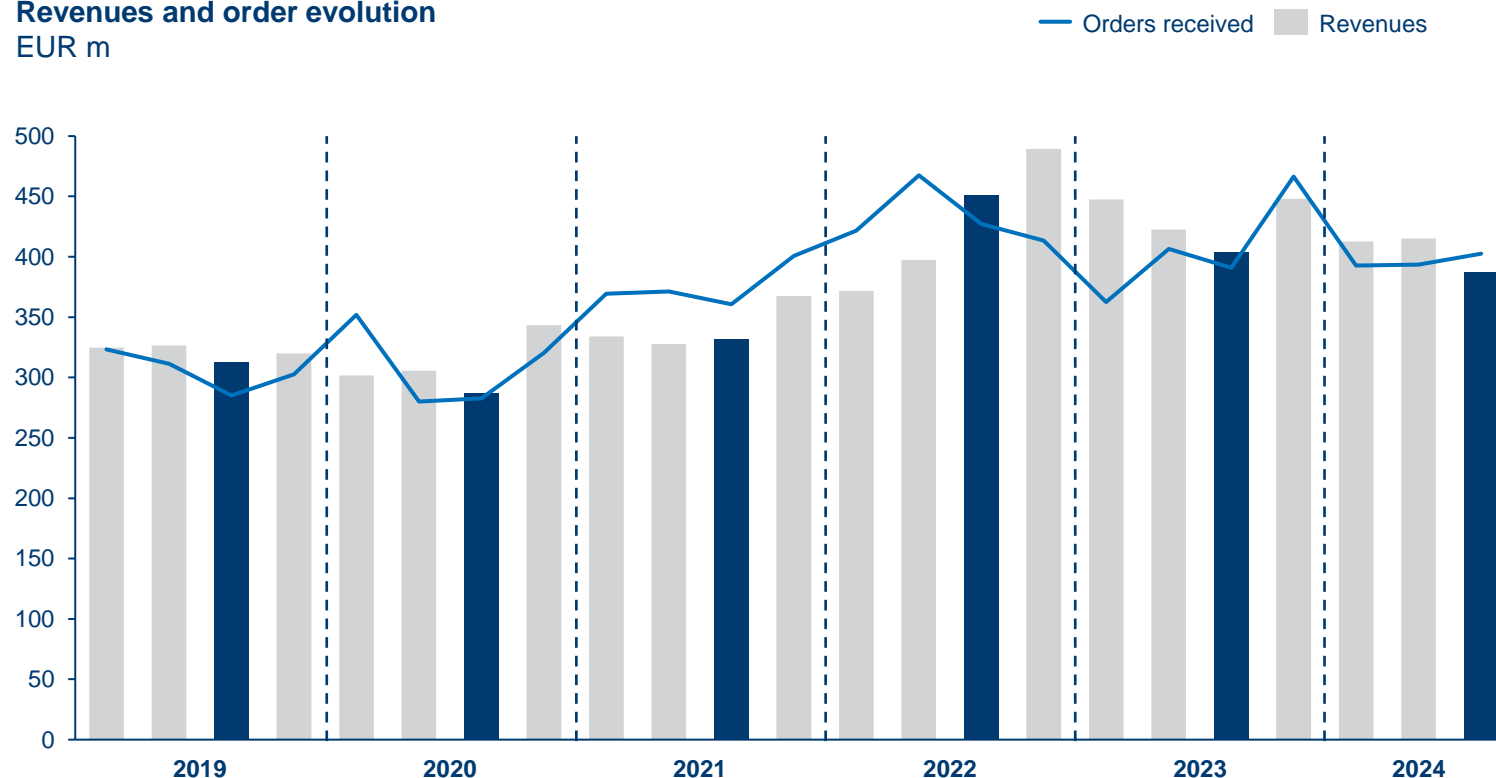

Operational performance

Gross profit

Gross profit margin 36.6% in the quarter (2Q24: 36.9%, 3Q23: 35.6%) despite a 6.8% drop in revenues driven by better mix and improved efficiency. Gross profit was EUR 141.7m in the quarter (2Q24: 153.2m, 3Q23: 143.5m).

Operating expenses (OPEX)

Operating expenses (OPEX) were EUR 105.5m in the quarter (2Q24: 115.5m, 3Q23: 107.2m). Continued focus on improvement efforts and cost discipline across the business, including personnel and non-product related spend. In the quarter there was also a release of accruals related to holiday, consistent with past practice.

OPEX as a percentage of revenues in 3Q24 was 27.3% (2Q24: 27.8%, 3Q23: 26.6%).

Further cost initiatives actioned in the quarter include footprint rationalization, lower personnel cost, and improved control on non-product related spend.

EBIT

EBIT¹ in 3Q24 was EUR 36.2m (2Q24: 37.7m, 3Q23: 36.3m), translating to an EBIT¹ margin of 9.4% (2Q24: 9.1%, 3Q23: 9.0%), despite lower revenue base.

EBIT improving year-over-year and sequentially to 9.4% despite lower revenue base, continued cost actions

EBITDA¹ and EBIT¹ development EUR m

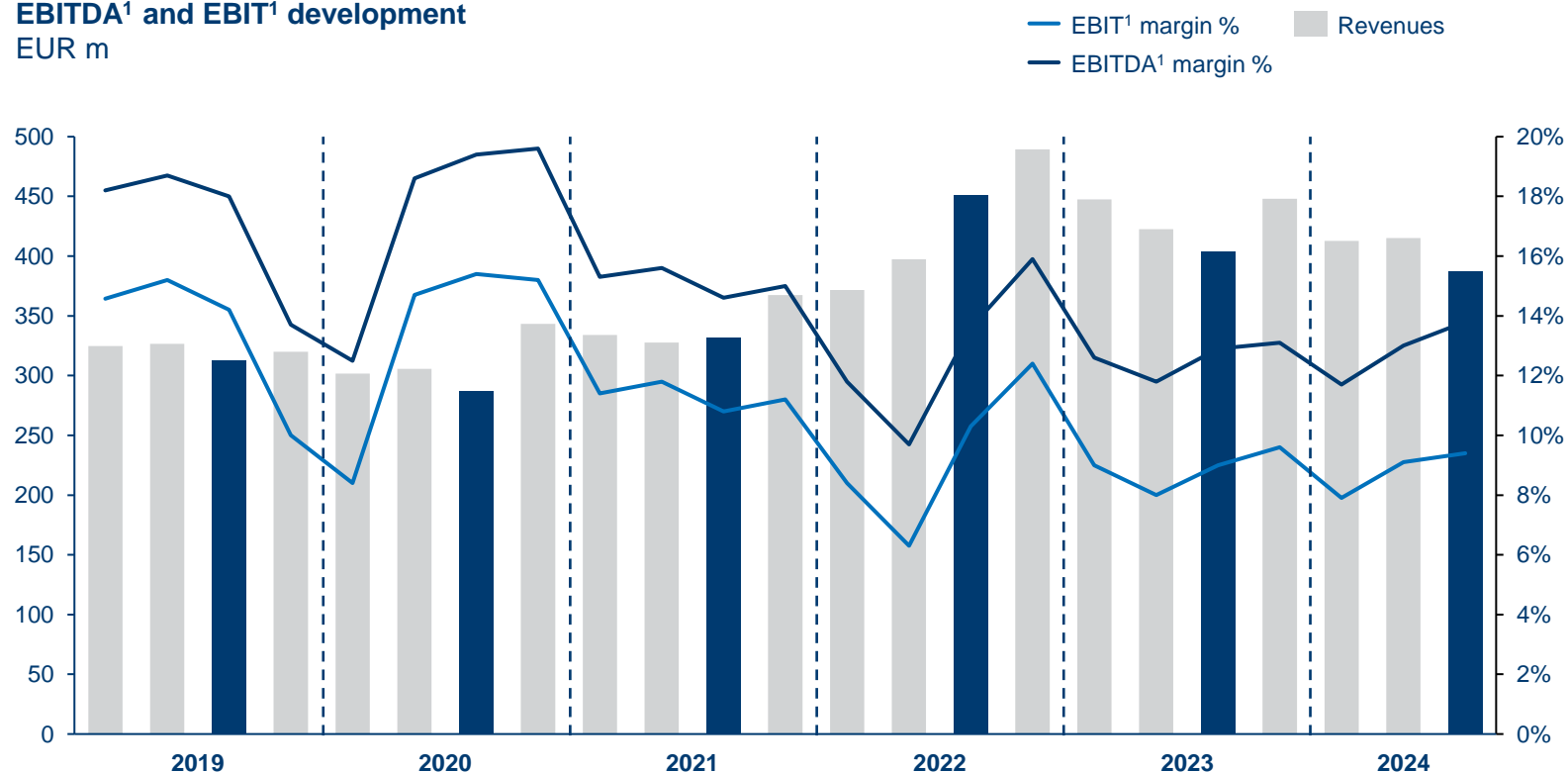

Notes: ¹ Result from operations and EBITDA adjusted for PPA related costs, including depreciation and amortization, acquisition related expenses and restructuring costs. In Q4 2023 and Q1 2024, result from operations is also adjusted for one-off write-offs related to product portfolio rationalization.

Diversified revenue base

Well diversified revenue structure across business segments, geographies and business mix

Revenues by segments
%

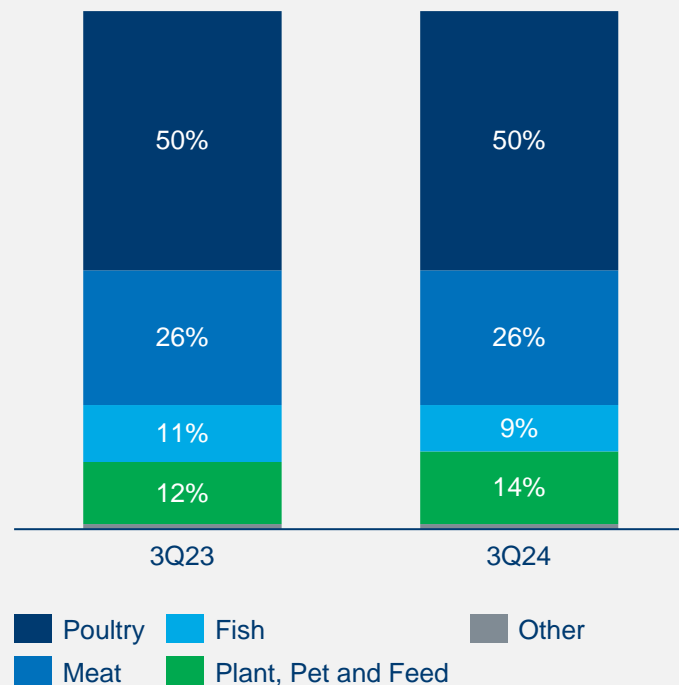

Revenues by geography
%

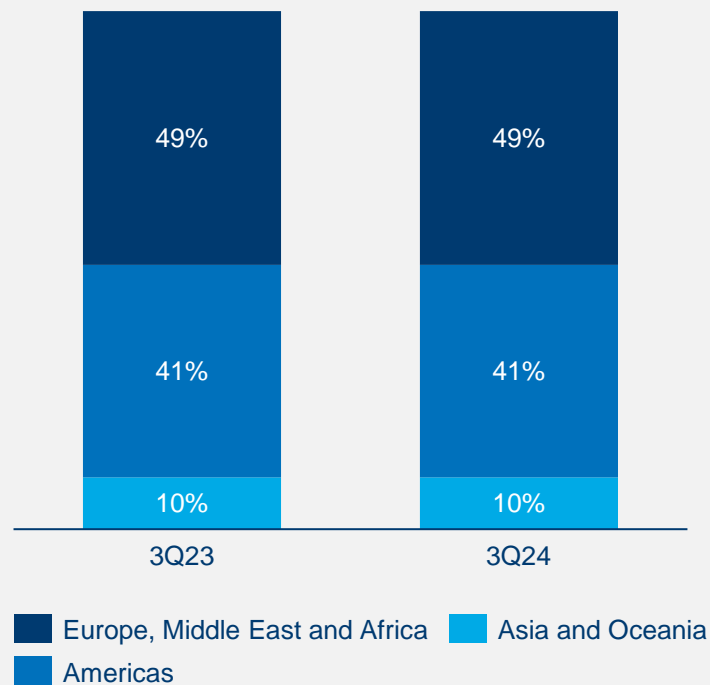

Revenues by business mix
%

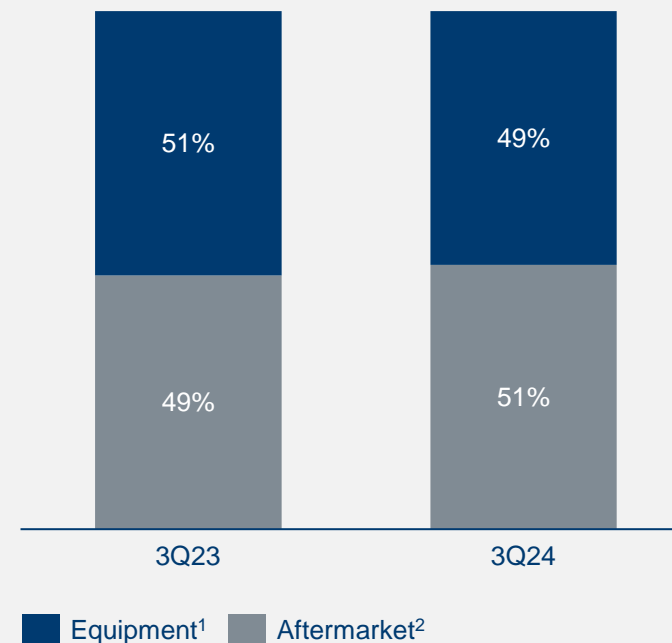

Order book development

Order book

EUR 554.1m up 2.9% QoQ and down 1.4% YoY

Positive improvement with order book moving upwards from a low level in 2Q24.

Book-to-bill in the quarter was 1.04 (2Q24: 0.95, 3Q23: 0.97).

Order book at quarter-end was soft at 33.3% of trailing twelve months revenues (2Q24: 32.1%, 3Q23: 31.9%) resulting from low project orders received in past quarters.

Order book needs to build up to deliver necessary revenue growth and improved operational performance.

Marel's order book consists of orders that have been signed and financially secured with down payments and/or letters credit.

Vast majority of the order book are greenfield and projects, while spare parts and standard equipment run faster through the system.

Low customer concentration with no customer accounting for more than 5% of total annual revenues.



Soft order book of EUR 554 million, or 33% of trailing twelve months revenues

Revenues and order evolution

EUR m

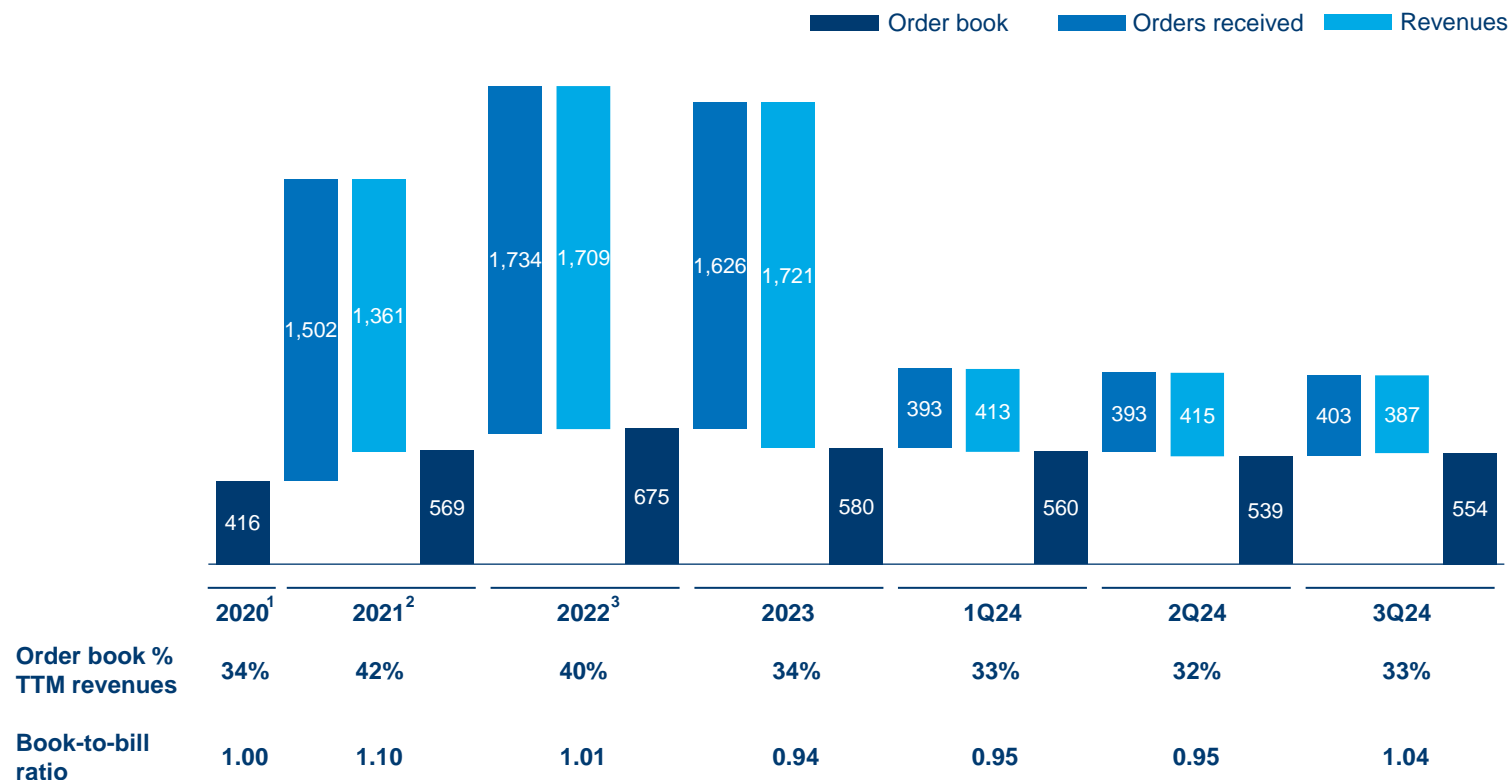

Notes: ¹ Including acquired order book of TREIF of EUR 5m. ² Including acquired order book of Curio, PMJ and Valka of EUR 12m. ³ Including acquired order book of Wenger and Slegers of EUR 81m.

Cash flow bridge

Operating cash flow

Operating cash flow was EUR 57.1m (2Q24: -4.0m, 3Q23: 62.4m).

Operating cash flow improved significantly since last quarter mainly attributable to improved net contract liabilities due to increased order book though partly offset by higher receivable position.

CAPEX¹ was EUR 4.5m (2Q24: 5.6m, 3Q23: 11.4m), or 1.2% of revenues in the quarter (2Q24: 1.3%, 3Q23: 2.8%), below a normalized level of 2-3% due to focus on cash flow after a period of elevated CAPEX levels into strategic investments in prior years.

Free cash flow was EUR 41.4m in the quarter (2Q24: -22.0m, 3Q23: 32.4m).

Leverage

Leverage³ was at 3.75x in the quarter (2Q24: 3.92x, 3Q23: 3.48x), and decreased QoQ due to lower net debt as a result of improved cash flow and FX movements.

The leverage covenant was 4.25x in 3Q24 with stepdown to 4.00x in 4Q24. Priority to reach targeted capital structure of 2-3x net debt/EBITDA.

Liquidity as of 30 September 2024 amounts to 348.7m consisting of cash on hand (EUR 62.7m) and committed credit facilities (EUR 286.0m).

Strong operating cash flow due to improved working capital

Cash flow bridge Q3 2024
EUR m

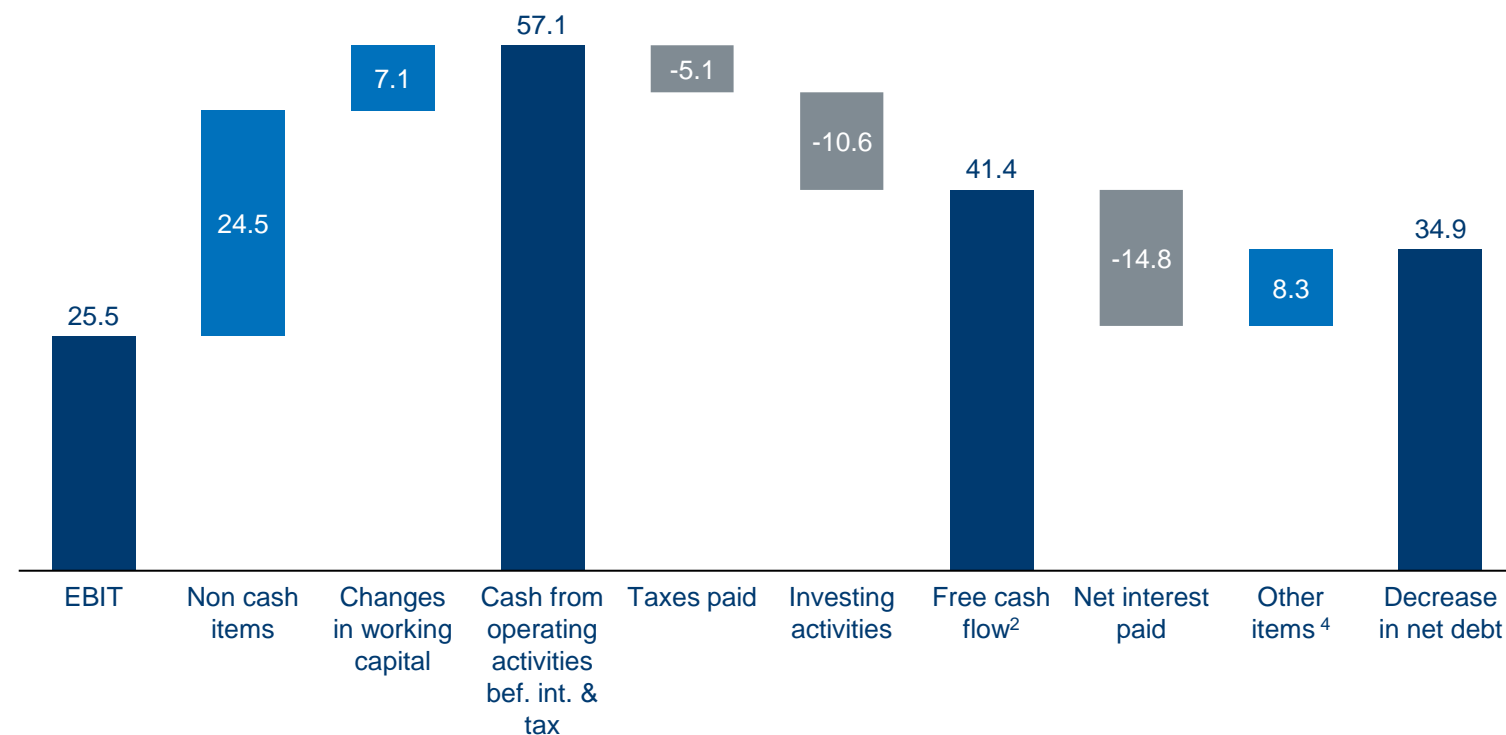

Marel Poultry

Orders received

- Very strong project orders received in 3Q24 with closure of some large projects. Market fundamentals continue to stay healthy and pipeline is good for coming quarters.

Revenues

- Revenues declined 7.6% QoQ and 6.1% YoY, due to softer orders received in previous quarters. However, the revenue decline was less than expected.

Operational performance

- EBIT¹ margin improved QoQ slightly above expectations on a lower revenue base with improved efficiency and a seasonally lower cost base.

Outlook

- Improved orders received has increased the order book which is an important step to deliver revenue growth in the future.
- With growth in orders received and order book, we expect gradual improvement in operational performance in 2025.
- Management continues to target margin expansion in the medium term with further build up of the order book for future revenue growth and operational improvement.

Operational performance stable despite QoQ revenue decline, compensated by lower costs. Healthy pipeline and good outlook

Revenues and EBIT¹, quarterly EUR m, %

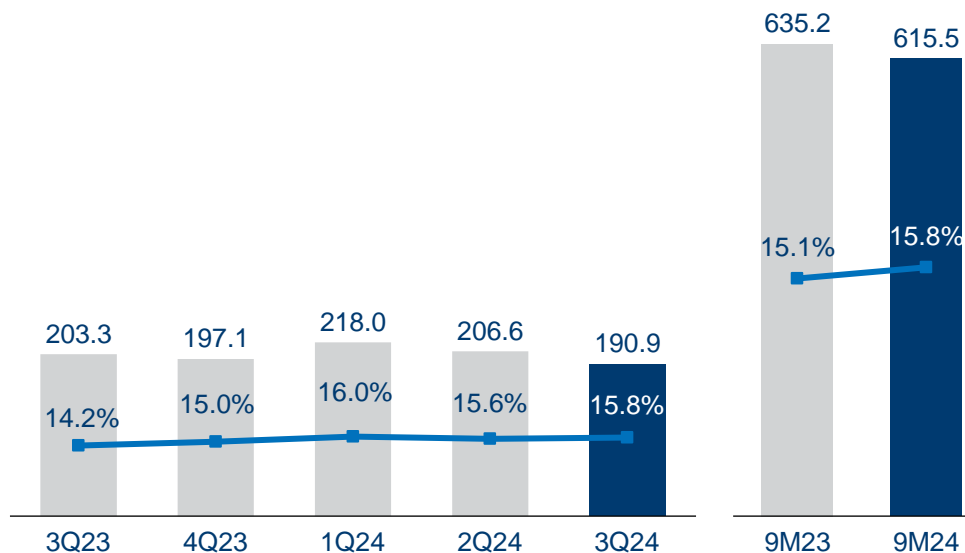

Q3 2024

Revenues

EUR 190.9m

50%

of total revenues

EBIT¹

15.8%

Marel Meat

Orders received

- Orders received were soft in the quarter mainly due to delay in projects to 4Q24 and 2025. Market fundamentals in Pork have shown some signs of improvement, especially in certain secondary processing solutions, while the market is still challenging.
- The market environment for Beef continues to be challenging given tight supply and high price levels. Current pipeline is soft and dependent on a few high-value projects, and timing of conversion to orders continues to remain uncertain.

Revenues

- Revenues were stable QoQ, down 1.3% with slightly lower equipment revenues, while aftermarket revenues remained resilient. Lower project revenues are a result of soft project orders received in recent quarters and the low order book.

Operational performance

- EBIT¹ margin improved QoQ and reached positive territory as a result of better mix and continued cost control initiatives.

Outlook

- Continued actions towards driving commercial activity and build up of the order book with a focused portfolio of value-added solutions, continued cost control and measures to improve profitability. Management targets margin expansion in the medium-term for Marel Meat, however the recovery will take time in light of the continued challenging market environment for the meat industry, in particular beef.



Improved operating performance on better margin and mix, and disciplined cost management. Soft orders and outlook colored by challenging market environment

Revenues and EBIT¹, quarterly
EUR m, %

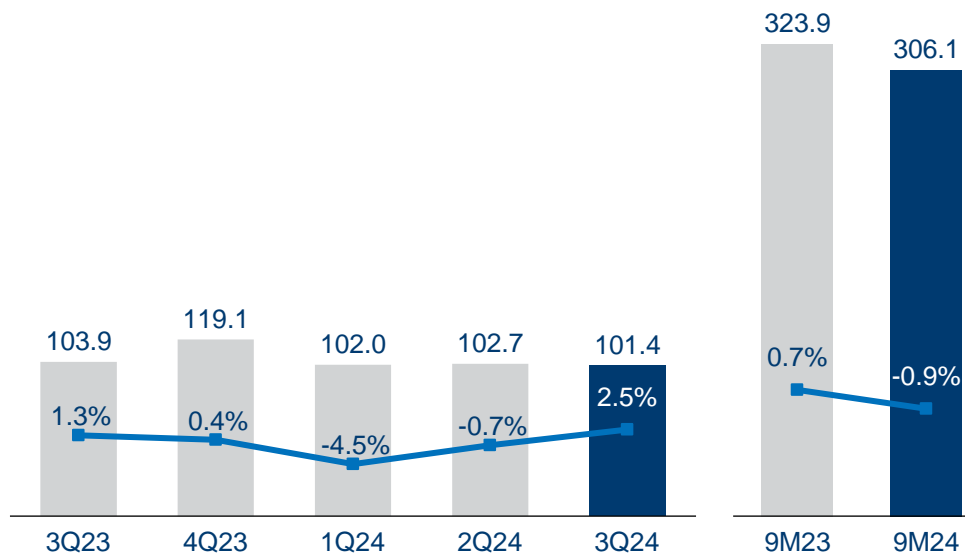

Q3 2024

Revenues

EUR 101.4m

26%

of total revenues

EBIT¹

2.5%

Notes: ¹ Result from operations and EBITDA adjusted for PPA related costs, including depreciation and amortization, acquisition related expenses and restructuring costs. In Q4 2023 and Q1 2024, result from operations is also adjusted for one-off write-offs related to product portfolio rationalization.

Marel Fish

Orders received

- Orders received were soft in the quarter and below expectations as orders are being delayed and large orders are still lacking.
- Fundamentals have been gradually improving in the salmon industry, while the white fish segment remains challenged. Uncertainty around timing continues to impact conversion to orders.

Revenues

- Revenues were down 19.4% QoQ and 20.7% YoY, due to soft order book and orders received.

Operational performance

- EBIT¹ margin was negative in the quarter, driven mainly by lower revenue base and headwind in mix due to cost overruns on a few projects from an acquisition. Operating cost discipline continues and reductions due to actions on work force and footprint are starting to flow through. Fish has completed consolidation of four production sites into one in Iceland.

Outlook

- Focus remains on improving profitability, increasing orders received and continued cost control.
- Management targets EBIT margin expansion for Marel Fish in the medium-term, with actions to increase commercial success to build up the order book and margin enhancing actions, focused on project control, operational efficiency and cost savings including optimizing manufacturing footprint.



Weak performance in 3Q24 due to soft order book and low revenues with unfavorable project mix

Revenues and EBIT¹, quarterly EUR m, %

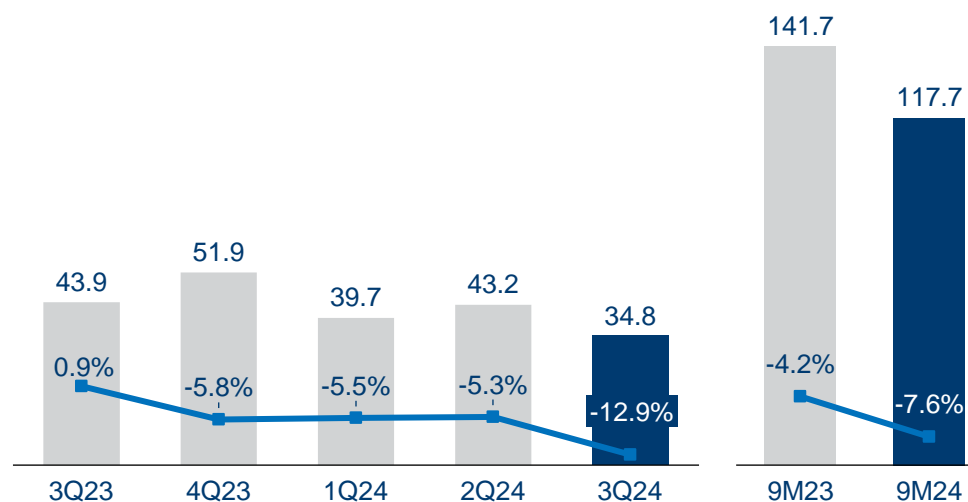

Q3 2024

Revenues

EUR 34.8m

9%

of total revenues

EBIT¹

-12.9%

Notes: ¹ Result from operations and EBITDA adjusted for PPA related costs, including depreciation and amortization, acquisition related expenses and restructuring costs. In Q4 2023 and Q1 2024, result from operations is also adjusted for one-off write-offs related to product portfolio rationalization.

Marel Plant, Pet and Feed

Orders received

- Orders received in 3Q24 were soft compared to a strong 2Q24, partially due to timing of orders.
- Fundamentals are solid and improving somewhat in the pet food industry, while the plant-based segment faces more headwinds with inflation and industry consolidation. Good pipeline, though timing of conversion to orders is uncertain.

Revenues

- Revenues declined slightly QoQ for both projects and aftermarket following a soft start of the year in terms of orders received.
- Revenues in 3Q24 were up 15.1% YoY, mainly driven by growth in project revenues.

Operational performance

- EBIT¹ margin driven by slightly lower volume and headwinds from mix.

Outlook

- Outlook remains solid for Marel Plant, Pet and Feed with good opportunities in the pipeline.
- Management's expectations for PPF's profitability is in line with historical performance.



Soft orders received in 3Q24 mainly due to timing while operational performance, pipeline and outlook remains solid

Revenues and EBIT¹, quarterly EUR m, %

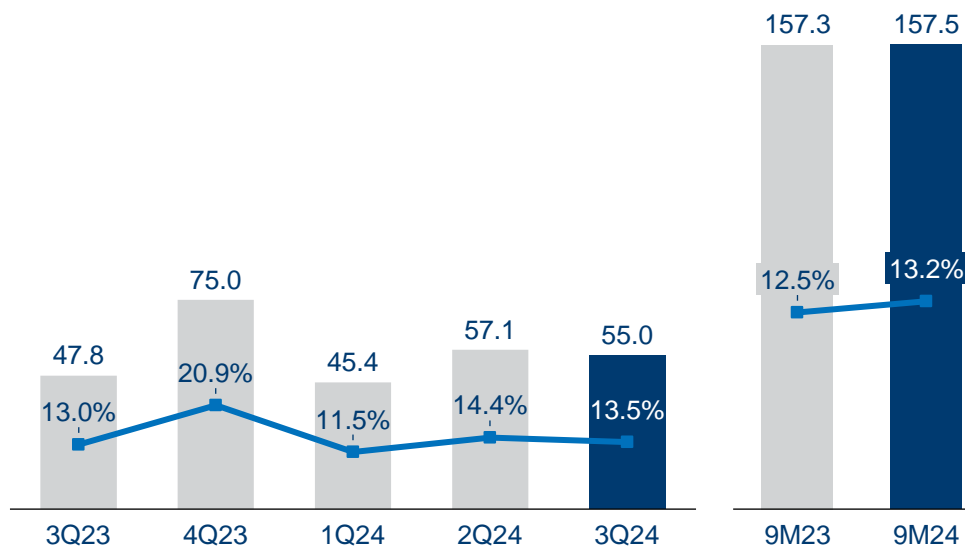

Q3 2024

Revenues

EUR 55.0m

14%

of total revenues

EBIT¹

13.5%

Notes: ¹ Result from operations and EBITDA adjusted for PPA related costs, including depreciation and amortization, acquisition related expenses and restructuring costs. In Q4 2023 and Q1 2024, result from operations is also adjusted for one-off write-offs related to product portfolio rationalization.

2

Outlook

Arni Sigurdsson
Chief Executive Officer

FY24 and mid-term outlook

Financial outlook	2023	2024	Mid-term
Revenues	1,721m		
Organic growth YoY %	-4.2%	Low single digit decline	Above market growth
EBITDA¹	217m		
EBITDA ¹ %	12.6%	13-14%	18%+
EBIT¹	153m		
EBIT ¹ %	8.9%	9-10%	14%+

Order book
Build up of order book to deliver strong revenue growth in the future

Leverage²
Focus on reaching targeted capital structure of 2-3x net debt/EBITDA

CAPEX³
2-3%

Working capital
Continued improvement

Assumptions

- Long-term average market growth of 4-6% annually.
- No material escalation of geopolitics or disruption in supply chain and logistics.
- Growth is not expected to be linear but based on opportunities and economic fluctuations, operational results may vary from quarter to quarter.
- Effective tax rate of ~20%.

Notes: ¹ Result from operations and EBITDA adjusted for PPA related costs, including depreciation and amortization, acquisition related expenses and restructuring costs. In Q4 2023 and Q1 2024, result from operations is also adjusted for one-off write-offs related to product portfolio rationalization. ² Net debt (excluding lease liabilities) / Pro forma LTM adjusted EBITDA (including recent acquisitions) excluding non-cash and one-off costs per Marel's credit agreement. ³ Capital expenditures excluding investments in R&D and right of use assets.

3

Update on JBT's offer launch

Arni Sigurdsson
Chief Executive Officer

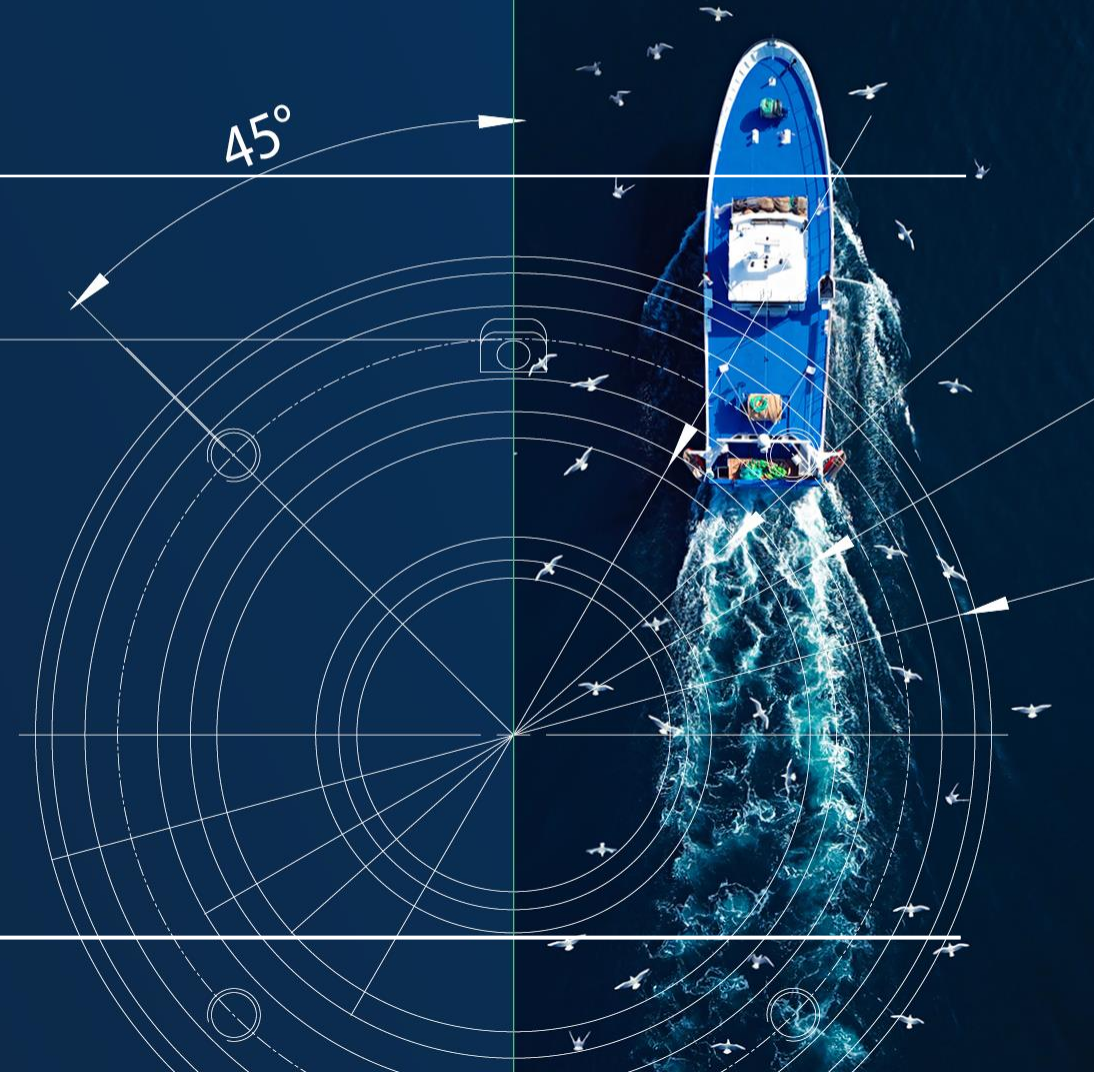

Proposed organizational design

JBT and Marel have started pre-integration planning for the proposed combination of the two companies. This includes a combined organizational design that best reflects our distinctive strengths with a clear focus on our customers

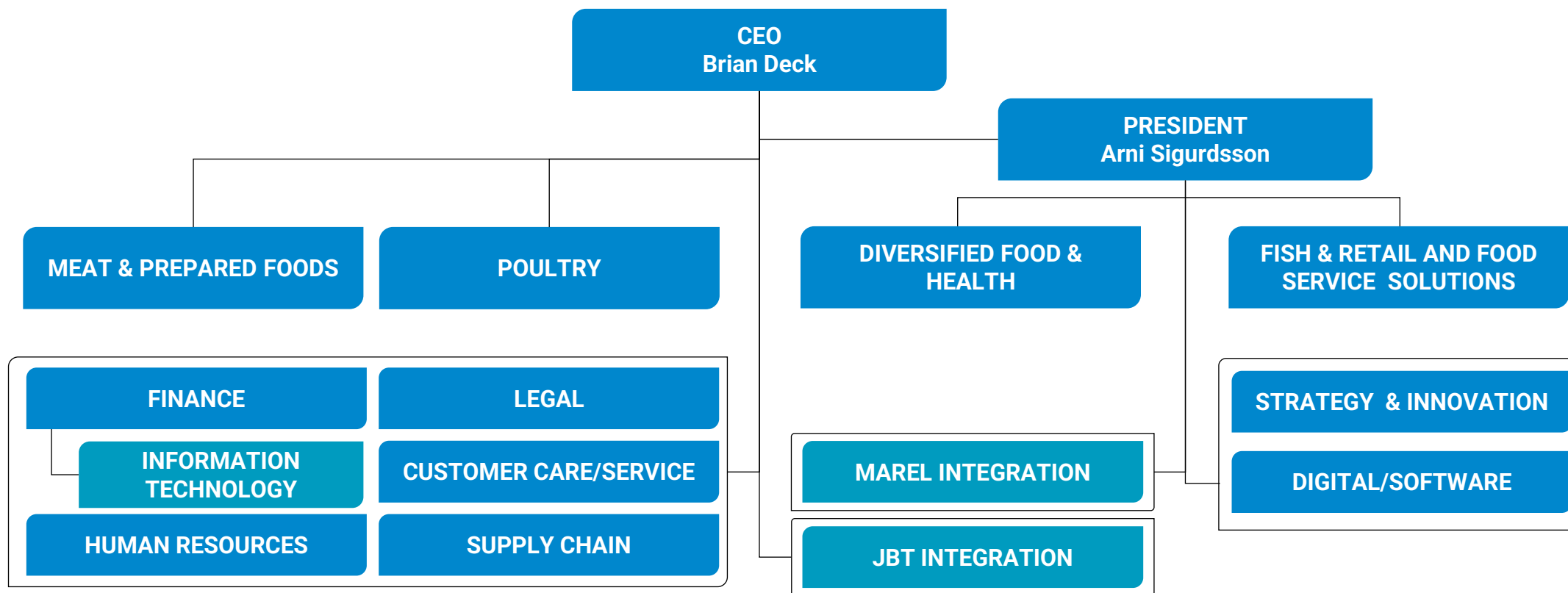

Four key business divisions

Four key divisions outlined to align on the combined value proposition and the structure that ensures the highest quality customer experience for our current and future customers

POULTRY

- Live bird handling
- Evisceration
- Waterjet portioning
- Chilling
- Cut-up/deboning
- Poultry skinning

FISH & RFS

- Inspection & Sorting
- Fish & Fillet processing
- Salmon slicing
- Injection & Tumbling
- Marination
- Cutting

MEAT & PREPARED FOODS

- Freezing & Cooking
- Frying & Coating
- Linking, Clipping
- Mixing/Grinding
- Tray sealing & Labeling
- Forming
- AGV
- Meat primary and cut-up & debone

DIVERSIFIED FOOD & HEALTH

- High Pressure Processing
- Filling & Closing
- Thermal Preservation
- Pet Food
- Fruit & Vegetable Processing
- Aseptic Processing
- Powder Processing
- Process Systems

Update on JBT's offer launch

Offer period extended to 20 December 2024 to align with European Commission regulatory filing process. The Marel Board unanimously supports the offer and recommends that the Marel shareholders accept the offer and tender their shares

- JBT targeting to close the transaction no later than 3 January 2025. JBT and Marel continue to make progress on the customary conditions to close the transaction
- Over 99% of shares voted at the JBT special shareholder meeting were voted in favor of the issuance of JBT shares for the Marel transaction
- JBT has secured a long-term financing contingent upon the completion of the merger
- Regarding regulatory workstreams, as of 23 October the European Commission has initiated their formal review of the regulatory filing subject to its standard 25 working day Phase 1 review period with a provisional deadline of 28 November 2024. Additionally, targeting to receive regulatory approval from Australian Competition and Consumer Commission during a similar timeframe to the E.C. approval
- JBT has received an extension from the Icelandic FSA regarding an extension of the voluntary takeover offer period to 20 December 2024
- Provided JBT achieves 90% acceptance, JBT plans to settle offer consideration within five Icelandic business days following offer expiration

	2024								2025	
	May	June	July	August	September	October	November	December	January	
Regulatory	Completed: Preparation and submission of required filings		Regulatory review						Year-end 2024: Target regulatory approvals prior to YE24	
S-4	16 May: Filed preliminary S-4	25 June: S-4 went effective								
JBT Stockholder Vote				8 August: JBT stockholders approved Marel transaction						
Voluntary Takeover Offer (VTO)		24 June: Launched VTO	Acceptance period extended to 20 December 2024					20 December: Expiration of the VTO		
Nasdaq Iceland Listing				August: Submitted request to begin secondary listing process	Preparation and review of Nasdaq Iceland application			Year-end 2024: Target secondary listing approval prior to YE24		

Targeting to close transaction no later than 3 January 2025, subject to receiving the remaining regulatory approvals, at least 90% of the outstanding Marel shares being tendered by Marel shareholders, and satisfaction or waiver of other closing conditions

Strong strategic rationale for JBT Marel



- 1 Markets:** Greater end market participation in resilient and growing food & beverage markets
- 2 Solutions:** Compelling platform to accelerate growth by offering broader solutions and holistic application knowledge, and leveraging R&D capabilities
- 3 Service:** Increased customer focus and aftermarket revenue opportunities as scale of global sales and service network will improve customer care reach and service levels
- 4 Digital:** Complementary leading digital tools provide insights to optimize and improve customers' operational efficiency, leading to reduced downtime events
- 5 Sustainability:** Greater collective impact on sustainability with innovative customer solutions rooted in reducing waste, energy efficiency, and improved food traceability
- 6 Talent:** Tremendous combined talent representing the best in the industry, with deep knowledge in technology, markets, and applications across various end markets
- 7 Scale:** Enhanced operational scale expected to generate meaningful value creation through operational efficiencies and cost synergies together with revenue synergies from cross-selling, enhanced service, and an overall improved value proposition

Q&A

Arni Sigurdsson
Chief Executive Officer

Sebastiaan Boelen
Chief Financial Officer



Investor Relations

Contact us

 +354 563 8001

 IR@marel.com

Follow us and join the conversation

 [@MarelGlobal](#)

 [Marel](#)

 [@Marel_IR / \\$MAREL](#)



Tinna Molphy

Director of Investor Relations



Marino Jakobsson

Investor Relations

Appendix

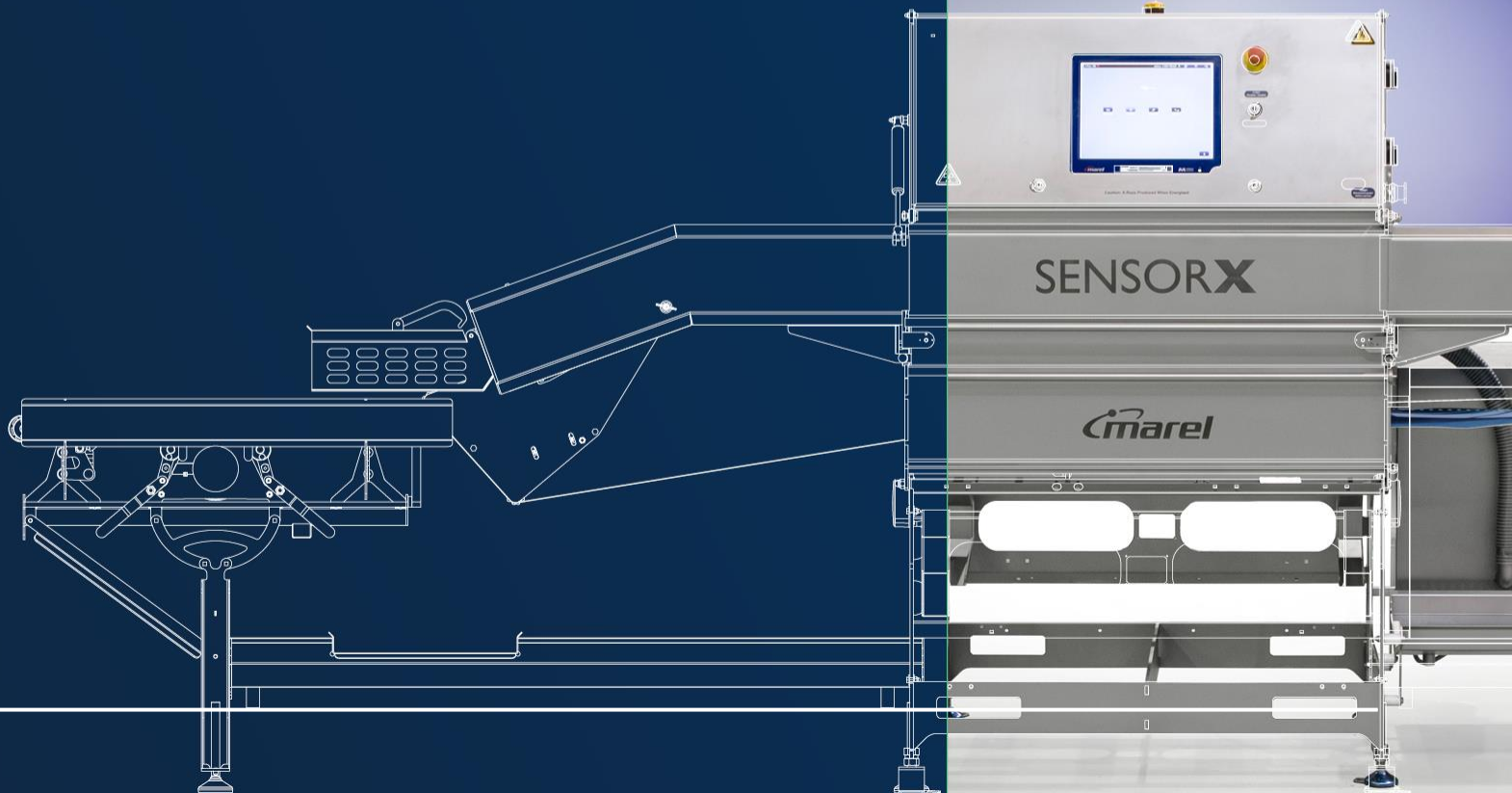

Income statement 3Q24

Revenues

EUR 387m

Gross profit

EUR 142m, or 36.6% of revenues

Adjusted EBIT

EUR 36m, or 9.4% of revenues

Net result

EUR 3.8m, or 1.0% of revenues



Condensed Consolidated Interim Financial Statements Q3 2024

Income statement

EUR m

	Q3 2024	Of Revenues	Q3 2023	Of Revenues	Change
Revenues	386.9		403.6		-4.1%
Cost of sales	(245.2)		(260.1)		-5.7%
Gross profit	141.7	36.6%	143.5	35.6%	-1.3%
Selling and marketing expenses	(53.5)	13.8%	(54.3)	13.5%	-1.5%
General and administrative expenses	(28.5)	7.4%	(28.6)	7.1%	-0.3%
Research and development expenses	(23.5)	6.1%	(24.3)	6.0%	-3.3%
Adjusted result from operations¹	36.2	9.4%	36.3	9.0%	-0.3%
Non-IFRS adjustments	(10.7)		(8.7)		+23.0%
Result from operations	25.5	6.6%	27.6	6.8%	-7.6%
Net finance costs	(17.8)		(15.1)		+17.9%
Share of result of associates	(0.1)		(0.0)		-
Result before income tax	7.6		12.5		-39.2%
Income tax	(3.8)		(2.4)		+58.3%
Net result	3.8	1.0%	10.1	2.5%	-62.4%

Notes: ¹ Result from operations adjusted for PPA related costs, including depreciation and amortization, acquisition related expenses and restructuring costs.

Balance sheet:

Assets

Inventories decreased by EUR 6.2m in the quarter.

Trade receivables increased by EUR 6.0m between quarters.

Contract assets increased by EUR 15.8m in the quarter, mainly due to timing of invoicing of projects, offset against contract liabilities to get to net contract liabilities.

Cash and cash equivalents increased by 33.0m in the quarter.

Condensed Consolidated Interim Financial Statements Q3 2024

Assets EUR m

	30/09 2024	31/12 2023	Change
Property, plant and equipment	331.9	345.8	-4.0%
Right of use assets	38.6	39.3	-1.8%
Goodwill	856.7	859.0	-0.3%
Intangible assets	522.0	541.2	-3.5%
Equity-accounted investees	3.5	3.3	+6.1%
Other non-current financial assets	3.5	3.5	-
Derivative financial instruments	-	0.6	-100.0%
Deferred income tax assets	41.9	38.9	+7.7%
Non-current assets	1,798.1	1,831.6	-1.8%
Inventories	334.8	352.5	-5.0%
Contract assets	51.0	36.3	+40.5%
Trade receivables	215.1	215.2	-0.0%
Derivative financial instruments	1.2	1.1	+9.1%
Current income tax receivables	7.3	7.3	-
Other receivables and prepayments	92.4	85.9	+7.6%
Cash and cash equivalents	62.7	69.9	-10.3%
Current assets	764.5	768.2	-0.5%
Total assets	2,562.6	2,599.8	-1.4%

Balance sheet: Equity and liabilities

Net interest bearing debt decreased by EUR 34.9m in the quarter due to improved cash flow.

Contract liabilities increased by EUR 33.2m in 3Q24 due to down payments from customers, offset against contract assets to get to net contract liabilities.



Condensed Consolidated Interim Financial Statements Q3 2024

Equity and liabilities EUR m

	30/09 2024	31/12 2023	Change
Group equity	1,036.3	1,041.6	-0.5%
Borrowings	840.7	819.8	+2.5%
Lease liabilities	30.1	29.8	+1.0%
Deferred income tax liabilities	82.9	84.9	-2.4%
Provisions	4.7	5.5	-14.5%
Other payables	2.7	2.7	-
Derivative financial instruments	3.7	3.4	+8.8%
Non-current liabilities	964.8	946.1	+2.0%
Contract liabilities	249.8	295.0	-15.3%
Trade and other payables	290.5	290.4	+0.0%
Derivative financial instruments	0.1	0.6	-83.3%
Current income tax liabilities	0.3	4.9	-93.9%
Borrowings	0.0	0.0	-
Lease liabilities	11.1	11.2	-0.9%
Provisions	9.7	10.0	-3.0%
Current liabilities	561.5	612.1	-8.3%
Total liabilities	1,526.3	1,558.2	-2.0%
Total equity and liabilities	2,562.6	2,599.8	-1.4%

Debt profile

As of 30 September 2024, interest bearing debt amounted to EUR 840.7m net of capitalized finance charges and excluding lease liabilities.

Marel has the following main funding facilities in place:

- EUR 700m Revolving Credit Facility (RCF) maturing in 2027
- EUR 18.5m Schuldschein notes maturing in 2025
- USD 300m term loan maturing in 2025 with two one-year extension options subject to lenders approval
- EUR 150m term loan maturing in 2025 two one-year extension options subject to lenders approval

Marel credit agreements contain restrictive covenants, relating to interest cover and leverage.

At 30 September 2024, Marel complies with all restrictive covenants relating to interest cover and leverage.

The leverage covenant is 4.25x in 3Q24 with stepdown to 4.0x for 4Q24.

Liquidity as of 30 September 2024 amounts to EUR 348.7m, consisting of cash on hand (EUR 62.7m) and committed credit facilities maturing in more than one year (EUR 286.0m).



Good covenant headroom and liquidity

Maturity profile 30 September 2024¹
EUR m

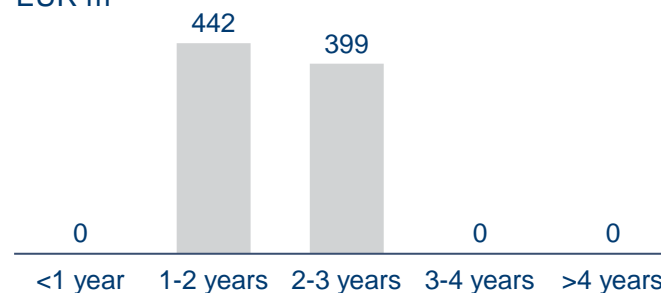

Leverage development

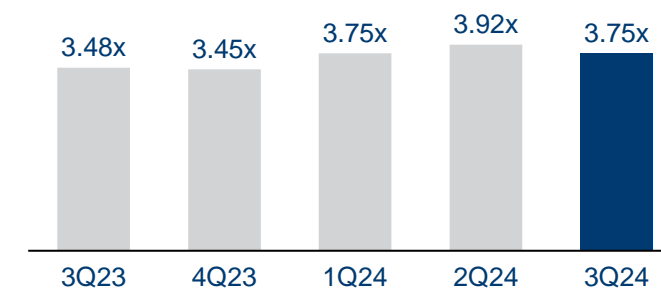

Currency split
%

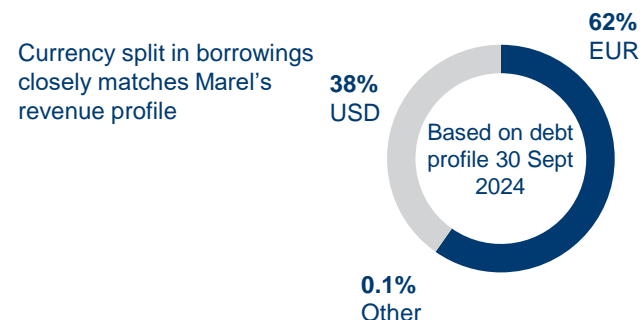

Fixed-floating profile
%

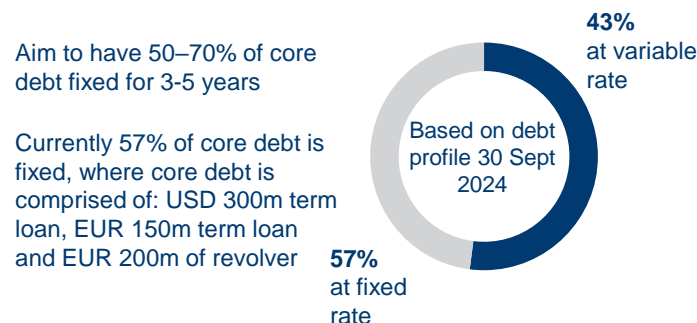

Notes: ¹ Net of capitalized finance charges and excluding lease liabilities.

Non-IFRS adjustments

Non-IFRS adjustments are made up of:

- I. Purchase Price Allocation (PPA) related charges, non-cash
 - Depreciation and amortization of acquisition related tangible and intangible assets
- II. Acquisition related expenses include fees paid as part of an acquisition process, whether the process resulted in an acquisition or not
 - Legal, consultancy, contingent payments and other costs
- III. Restructuring costs
 - One-off costs related to profit improvement initiatives
- IV. Other in 4Q23 and 1Q24 are impairment charges due to product portfolio rationalization

In 3Q24, PPA related charges were EUR 6.7m.

Quarterly PPA related charges expected to be around EUR 7.0m in coming quarters.

Non-IFRS adjustments on EBIT and EBITDA

Non-IFRS adjustments breakdown

EUR m	3Q24	2Q24	1Q24	4Q23	3Q23
PPA related charges	6.7	6.9	6.7	6.8	6.8
Acquisition related expenses	1.3	3.9	8.1	1.1	0.4
Restructuring costs	2.7	3.4	4.4	2.0	1.5
Other – portfolio rationalization	-	-	1.7	7.1	-
Total non-IFRS adjustments	10.7	14.2	20.9	17.0	8.7

Adjusted EBIT reconciliation

EBIT	25.5	23.5	11.9	25.8	27.6
PPA related charges	6.7	6.9	6.7	6.8	6.8
<i>Depreciation and amortization of other acquisition related assets</i>	6.7	6.9	6.7	6.8	6.8
Acquisition related expenses	1.3	3.9	8.1	1.1	0.4
Restructuring costs	2.7	3.4	4.4	2.0	1.5
Other	-	-	1.7	7.1	-
Adjusted EBIT	36.2	37.7	32.8	42.8	36.3

Adjusted EBITDA reconciliation

EBITDA	49.3	48.2	35.6	54.8	50.2
Inventory uplift related PPA charges	-	-	-	-	-
Acquisition related expenses	1.3	3.9	8.1	1.1	0.4
Restructuring cost	2.7	1.7	4.4	2.0	1.5
Other	-	-	-	1.0	-
Adjusted EBITDA	53.3	53.8	48.1	58.9	52.1

Disclaimer

Forward-looking statements

Statements in this press release that are not based on historical facts are forward-looking statements. Although such statements are based on management's current estimates and expectations, forward-looking statements are inherently uncertain.

We therefore caution the reader that there are a variety of factors that could cause business conditions and results to differ materially from what is contained in our forward-looking statements, and that we do not undertake to update any forward-looking statements.

All forward-looking statements are qualified in their entirety by this cautionary statement.

Market share data

Statements regarding market share, including those regarding Marel's competitive position, are based on outside sources such as research institutes, industry and dealer panels in combination with management estimates.

Where information is not yet available to Marel, those statements may also be based on estimates and projections prepared by outside sources or management. Rankings are based on sales unless otherwise stated.



Thank you

